



<https://asml.ui.ac.ir/>

Identification of Barriers to Attracting and Retaining Sports Donors in the Field of Women's Sports Infrastructure Development in Isfahan Province

Leila Moslehi ¹

1. Faculty of Physical Education and Sport Sciences, University of Tehran, Tehran, Iran,
Email: leila.moslehi@ut.ac.ir, (corresponding author)

Article Info	Abstract
<p>Article type: Research Article</p> <p>Received: 18 March 2023</p> <p>Accepted: 16 June 2023</p> <p>Published online: 25 June 2023</p>	<p>Considering the importance of sports and physical activity for women and the necessity of involvement of economic structures to advance the goals in this area, the present research was conducted with the aim of identification of obstacles of attracting and retaining sports donors in the field of women's sports infrastructure development in Isfahan province. This research is an applied research and it is mixed (qualitative-quantitative) in nature. The method of data collection in the qualitative part was the opinion of experts using the Delphi method, and in the quantitative part, a researcher-made questionnaire was used. The statistical population of the research in the quantitative part included all active benefactors of Isfahan province, members of the faculty of sports management and sociology and Islamic sciences, and managers of endowment and charity offices in Isfahan province. In the benefactors and managers section, the available cases were selected and in the faculty members section, the selection was done in a simple random manner. Barriers were identified first based on library studies and then based on the opinions of experts (Delphi method). Confirmatory factor analysis was used to determine the contribution of each barrier. Based on the obtained results, the fit of the model of barriers to attracting and retaining sports donors in the field of women's sports infrastructure development in Isfahan province was confirmed with five managerial, economic, cultural, legal and informational barriers and finally, the proposed strategies were presented in order to remove the obstacles.</p>
<p>Keywords:</p>	Benevolent, Donor, Sport Development, Women's Sport
<p>Cite this article:</p>	Moslehi, L. (2023). Identification of Barriers to Attracting and Retaining Sports Donors in the Field of Women's Sports Infrastructure Development in Isfahan Province. <i>Archives in Sport Management and Leadership</i> , 1(1), 81-91. doi: 10.22108/jhs.2023.137232.1017



Introduction

Since the 1970s, sport has assumed an increasing role in the globalization of business and public events, with sports participants, capital and labor all over the world (Zhang et al., 2018). The importance and popularity of sports in the last 50 years has created a new industry called the sports industry, and in the last three decades, a significant growth has been observed in this industry (Nuseir, 2020). As an important part of the national economy, the sports industry plays a major role in adjusting the economic structure, stimulating economic growth, expanding employment channels, and promoting the development of related industries (Zhao, 2022). Sports economy is a broad field that has a close relationship with other economic sectors (Syed Ameri et al., 2009). Today, the economic activities of countries are generally formed in three sectors: private (first sector), government (second sector) and charity organizations (third sector). In the meantime, the third sector of the world economy is expanding and becoming more important day by day. The voluntary motivation based on self-sacrifice and altruism of third sector institutions makes the economy more efficient than private institutions, and its lower costs compared to the public sector, in providing social and non-profit services, causes the increasing attention of societies to this section. The third part of the economy includes altruistic interactions and includes organizations and institutions that 1) are formed and maintained by a group of people and are set up voluntarily and without regard for personal benefit; 2) People control and manage it; 3) any benefit and profit from the activities are spent towards the set goals, and personal profit and organizational benefit are not considered (Taheri Demneh and Heidari Darani, 2018). Donors' motives can be evaluated in dimensions such as philanthropy, showing commitment, affiliation, recognition (Ko et al., 2014), good feeling, perceived effectiveness of financial aid (Filo et al., 2019); Meanwhile, religious beliefs lead to a greater desire for benevolent forgiveness (Kim and Walker, 2013), and this is very important in our country.

In most societies, benefactors have helped the needy in various ways; in such a way that some of the most important universities in the world such as Harvard and Oxford are endowments and continue to benefit from the help of benefactors (Afroozeh et al., 2018). In Iran, until the Qajar era, the desire of the people and kings was more to build religious schools, and after learning about western schools, they showed a desire to build western-style schools. Similarly, Muzaffaredin king dedicated one of Iran's mines to provide fuel for schools (Shah Hosseini, 2010). In addition, in the Islamic society, the philosophy of promoting charity and the institution of devotion in Islam have always been considered as a good tradition, to fill the gaps and solve the cultural, social and economic needs (Afroozeh et al., 2018). Despite the rich culture of devotion in the country, the position of sports in this field is not satisfactory; In this regard, according to the results of Hasan Shahi et al.'s research (2017), only 4.1% of benefactors in the field of sports have a history of philanthropy and this is while 43.7% of the benefactors have contributed to the mosque and 14.6% have contributed to the construction of the school.

Studies show that charity and social responsibility have been the main pillars of professional sports for more than 50 years (Abuin-Penas et al., 2020). Filo et al. (2010) state that due to the potential in sports and sports events, in some countries, many charitable organizations try to gain more popularity by associating themselves with sports, and at the same time, Collect more donations. Sports and related activities are very attractive for collecting donations and voluntary charity work; because it provides an opportunity to participate in two important things (sports and charity affairs) at the same time (Wooda et al., 2010). Nowadays, many efforts are made to bring sports and sports events to the attention of benefactors; even, if the sport is used to meet other needs of the society (Bunds et al., 2016). Inoue et al. (2017) claimed that the social effects of sports events that have emerged with the support of benefactors and charities can develop social capital, increase identity, collective pride, and finally, promote sports, health and well-being (Ino et al., 2017). The dedication and participation of benefactors in sports can be interpreted in different parts, such as in the form of the development of sports spaces.

Achieving desirable results in the field of attracting and persuading donors to develop sports infrastructure requires extensive planning based on scientific research and adaptation of programs to the basic needs of society. In the meantime, it is clear to everyone that it is not possible to achieve this without considering women who make up more than half of the country's population. Among the effects of physical

activity on the physical aspect of women, we can also mention the effect of exercise during pregnancy. As the research results of Filipec and Matijević (2022) showed, regular exercise leads to specific adaptation processes of body systems, which improves the physical and mental health of pregnant women and has a positive effect on her fetus. One of the most important positive psychological consequences of exercise includes freshness and mental relaxation, increasing self-confidence and prevention of depression in women. In this regard results of the research by Murphy (2021) and colleagues showed that the effect of physical activity on reducing depression in women was greater than in men. Although the effects of physical activity on physical structure and its psychological effects in women are not less than in men, it seems that in our country, due to the existence of restrictions and inhibiting factors, women face a serious problem of inactivity (Salimi et al., 2022).

Looking at the history of sports in the world, we can see that throughout history, sports have always been considered a male domain, and its standards and values have all been formed based on men, which are influenced by the culture and social capital of people in societies. Among the various forms of discrimination in women's sports in the world and in Iran, including wage inequality, inequality of available sports facilities for the promotion of female athletes, and the allocation of a low percentage of the sports budget to women can be mentioned (Nazari Azad et al., 2020). The lack of clarity of duties and the lack of clarity of the position of women's sports in the field of sports management, as well as not valuing women's special sports venues and not supporting financial sponsors have slowed down the progress in women's sports (Pourgachi et al., 2017). The state of women's sports and their participation in sports reflects the political and social status of women in the country; therefore, the policies adopted regarding women's sports have global implications for the Islamic Republic of Iran, while the results of internal research show the fact that limited companies are willing to invest in women's sports (Jamaat and Ehsani 2011). This shows the need for targeted management and planning in this field, considering the special conditions and characteristics of women's sports. In this regard, one of the areas that require special planning and supervision in the women's sector is the issue of investment and budget entry in this area. But there are many problems in women's sports; In this context, we can mention the political problems, economic obstacles, the government's policy of not prioritizing the participation of women in sports activities and the lack of proper alignment of the media with women's sports (Pourgachi et al., 2017), which All these things can affect the willingness to invest in this field.

Strelize (2005) considers the role of television shows in attracting financial sponsors essential and believes that the wider the television and satellite broadcasts of sports competitions at the national and international levels, the more sponsors will be attracted (Seyed Bagheri and Sharifian, 2017). This is despite the fact that many research studies in the country have shown that male and female athletes are covered and treated differently by the media (Pourgachi et al., 2017). Sociologists in the field of sports say that although the media has provided opportunities for women to be more active, women athletes are much less noticed in terms of media coverage and researchers have reached the same results about media coverage of women's sports (Hamidpour and Shetab Booshehri, 2015). Ehsani et al. (2008) investigated the causes of sponsors not supporting the professional sports of women in Isfahan city. The results of this research showed that the companies do not reach their goals in supporting women's sports, including increasing the sale of goods and services, creating a suitable image of the company in the public mind, competing with other companies, and expanding the number of sales (Ehsani et al. 2008).

In most developed countries, charitable organizations are considered a very important part and often engage in activities that governments are unwilling and unable to do and the private sector does not have the necessary motivation to enter the field of such activities. Considering the problems that women have to attract capital in sports, one of the areas that can help them is dedication and charity. Donors' goals are mainly in line with social responsibility and non-economic benefits, which justifies supporting women's sports considering its valuable results (Taheri Demneh and Heydari Darani, 2018). Considering the many obstacles of women's sports, especially in attracting financial resources, sufficient planning and monitoring should be done to achieve the benefits of sports for this segment of the society through sports donors. Therefore, in this research, the researcher seeks to answer the question of what are the obstacles to attract

and retain sports donors in line with the development of women's sports infrastructure in Isfahan province and finally based on the obtained results, the proposed solutions are mentioned.

Research Methods

According to the nature of the required information, this research was conducted with a combined (qualitative-quantitative) method. Delphi method was used in the qualitative part and confirmatory factor analysis was used in the quantitative part. In the first step, library studies through the review of scientific and documentary sources including articles, books and authoritative sites using key phrases including financial support in sports, attracting financial resources in sports, financial support for women's sports, endowment in sports, obstacles to endowment in sports, barriers to financial support in women's sports and barriers to the development of women's sports were conducted to identify barriers effective in maintaining and attracting sports donors in order to develop the infrastructure of women's sports. In the second stage, the Delphi technique was used for theoretical consensus about the barriers and the items related to each obstacle.

The members of the Delphi panel were 12 professors of the faculty of sports management and sociology. The statistical population of the research to answer the questions of the questionnaires includes all active benefactors of Isfahan province, members of the faculty of sports management and sociology, and managers of endowment and charity offices in Isfahan province. Due to the lack of accurate information on the total number of people in the mentioned communities, the sample size was determined based on the table of Karjesi and Morgan, and in this table, the introduced sample for the unknown community is 384 people. In the benefactors and managers section, the available cases were selected and in the faculty members section, the selection was done in a simple random manner in each field.

Based on the results of the Delphi technique, a research questionnaire was developed. The content and form validity of the questionnaire was examined and confirmed based on the professors' opinion. At this stage, based on the opinion of the professors of 2 items, which were conceptually related to the obstacles of attracting and maintaining financial resources in women's sports infrastructure, their concepts were changed specifically in relation to the obstacles of attracting and maintaining financial resources of sports donors. Reliability was examined and confirmed through Cronbach's alpha. The reliability coefficient of the questionnaire was obtained as 0.85, which indicates the optimal reliability of the questionnaires. Based on this, the research questionnaire consists of 5 indicators (barriers), including managerial barriers (5 items), cultural barriers (5 items), informational barriers (5 items), legal barriers (5 items) and economic barriers (4 items) and in general 24 items were compiled. 100 questionnaires were distributed manually and questionnaires were sent online to 350 people, and finally 385 questionnaires were used for data analysis. It was necessary for the respondents to express their opinion regarding importance of each item in a 5-point Likert scale (from very much to very little).

Finally, confirmatory factor analysis was used to determine the contribution of each barrier. SPSS 22 and AMOS 22 software were used for data analysis.

Findings

The output of the Delphi technique implementation process after 3 stages of referencing questionnaires including 24 items in the form of 5 Barriers (management (5 items), cultural (5 items), informational (5 items), legal (5 items) and economic (4 items) was identified, the results of which are presented in Table (1).

Table 1- Barriers to attracting and retaining sports donors in the field of women's sports infrastructure development

Barriers	Items
Managerial	Lack of strategic thinking in the development of women's sports facilities by donors
	Lack of effective coordination between different sectors in urban development in the field of women's sports facilities, including the public sector, private sector and donors
	Lack of managers with concern and motivation in the development of women's sports to

	employ donors
	Abandonment of charitable support plans in the development of sports spaces due to management changes
	Managers' lack of awareness of the potential of endowment and charity work in the field of sports space development
Cultural	Lack of a suitable model for endowment in sport
	Weak social attitude in the field of women's sports
	Lack of positive attitude in achieving spiritual reward in investing in sports compared to other fields
	Weak cultural background in the field of dedication and charitable affairs in sports venues
	Lack of positive view of benefactors towards sports due to moral anomalies or cultural-religious weakness in sports venues
Informational	Weakness in holding conferences, seminars and scientific courses in the field of dedication and charitable affairs in sports
	Weakness in creating a culture of endowment in sports in general and women's sports in particular in the media
	Lack of informing and increasing benefactors' awareness of the potential and benefits of endowment in the field of sports
	Lack of proper awareness of the benefits of endowment in sports in the field of health
	Lack of organized advertising by relevant bodies in the field of sports charity in public places
Legal	Lack of legal facilitators for investing in women's sports facilities
	Existence of legal obstacles for investment for construction by donors
	The lack of transparency of the law in the field of endowment and investment for the development of urban areas
	Absence of legal requirements for government support of sports donors
	Legal weakness in coordination between sectors (government, private and donors) in the development of urban areas
Economic	The high price of land
	High maintenance costs of sports facilities
	The high price of sports equipment
	Absence of exceptional financial support from the government in supporting donors in the construction of sports facilities

Before conducting factor analysis, it is necessary to ensure the appropriateness of the number of samples and also the relationship between variables for analysis. For this purpose, two tests "Kaiser-Meyer-Olkin" (KMO) and Bartlett's test were used. Kaiser (1974) recommends a bare minimum of 0.5 and the value between 0.5 and 0.7 are mediocre, value between 0.7 and 0.8 are good, value between 0.8 and 0.9 are great and value between 0.9 and above are superb (Hutcheson & Sofroniou, 1999). In relation to the Bartlett test, if there is no significance, there is a possibility that the matrix Correlation is inappropriate for analysis. Table (2) shows the results of the KMO test and the Bartlett test.

Table 2- KMO index and Bartlett's test

KMO index	0/900	
Bartlett's test	4437/89	Chi-square index
	383	Degree of freedom
	0/001	Significance level

According to the results presented in table (2), the numbers of samples as well as the relationship between the variables are confirmed for factor analysis. The indicators related to model fit are presented in table (3).

Table 3- Indicators related to model fit

Index	Acceptable Range	The Amount Obtained
X2/DF	smaller than 3	1/924
CFI	More than 0.9	0/944
TLI	More than 0.9	0/932
IFI	More than 0.9	0/945
PNFI	More than 0.5	0/734
RMSEA	Less than 0.08	0/066
PCFI	More than 0.5	0/777

Examining the obtained values according to the acceptable range of each index in the table (3) shows that the obtained values are within the acceptable range in relation to all the indices, so the fit of the model is confirmed. The factor analysis model of the barriers to attract and retain sports donors in the field of women's sports infrastructure development can be seen in Figure (1).

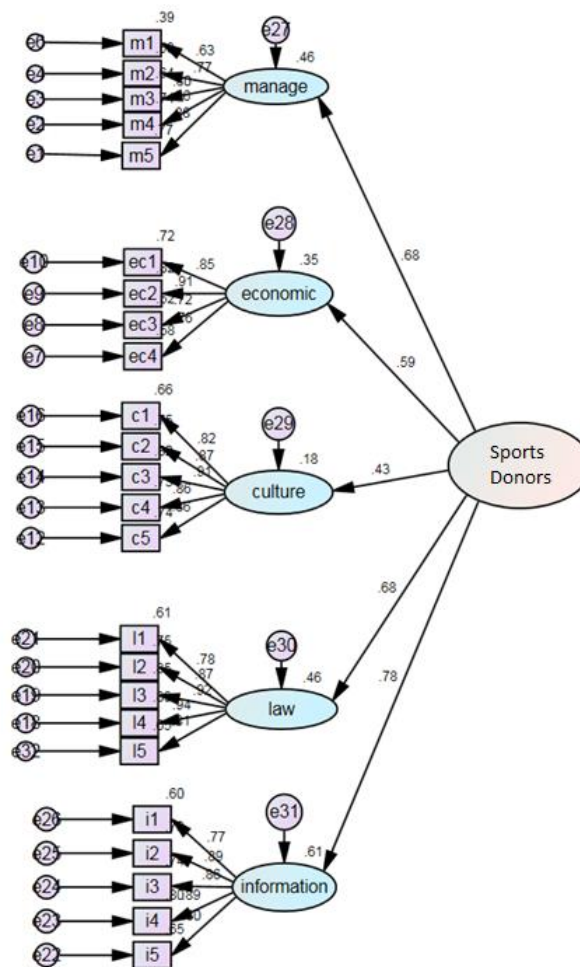

Figure 1- Second-order confirmatory factor analysis model in standard mode

Discussion

In the current research, the barriers to attract and retain sports donors in the field of development of women's sports infrastructure in Isfahan province were introduced in the form of 5 components including managerial, cultural, informational, legal and economic. based on the result Asadi Jannati et al. (2019) inadequacy of legal mechanisms, lack of proper and continuous communication with donors, problems in the field of management and optimal allocation of resources, and insufficient awareness of donors about the priorities were the most important barriers of efficient and effective participation of benefactors in the field of health that its result is in line with this article.

From the point of view of experts, managerial barriers were identified as one of the most important barriers to attract and retain financial sponsors in the development of women's sports infrastructure that its role was confirmed in a quantitative analysis. The lack of proper organization for endowments is one of the important and influential factors in the lack of development of the endowment category in Iran, which is contrary to many countries that are active in this field. For some time, endowment in Iran has fallen from its past prosperity, and one of the main reasons for this slowness and stagnation can be summed up in the lack of proper organization for endowment; In other words, there is no effective organization and endowment guidance system for the proper management and use of endowment properties or the creation of assets needed by each region and its people. Therefore, the lack of proper management in the field of endowment is one of the important and influential factors in the lack of development of the endowment category in Iran, and the weakness of management in the field of endowment and charitable affairs can be generalized to the sports sector. As the results of Hosseini et al.'s research (2013) showed, improving the current management methods governing the endowment property in the endowment organization has an effect on the efficiency of the endowment. Based on the results of Khaksar Astana et al.'s research (2015), the strategic program in the field of endowments and competitors are management challenges in this field. The officials' lack of initiative, the officials' lack of support, and the lack of cooperation of other departments were among the obstacles identified in the research of Heidari Fard and Sharifian (2017) in identifying obstacles to the participation of donors in the development of sports spaces, which are related to the management obstacles identified in the present research. By removing the managerial obstacles, it is possible to use the maximum potential for the development of women's sports through correct and targeted planning and the use of innovation and intelligence in the strategies of attracting and retaining donors. In this regard, as Filo et al. (2022) point out, the use of online fundraising has become a vital aspect of the charitable sports event experience. On this basis, the use of new technologies and the holding of charity sports events are considered as two strategies for attracting donors. To overcome managerial obstacles, having a goal and a vision of developing sports infrastructure (especially in the women's sector) through endowment and charity, as well as providing and applying strategies and adequate supervision are suggested management steps. These measures are necessary to achieve the potential of the third sector of the country's economy in the development of sports facilities; also, using the phenomenon of synergy in the development of sports infrastructure for women can lead to fruitful results. Considering the role of each of the bodies (such as legislators, municipalities and the media) in the field of facilitating the support of donors in the field of sports, synergy and coordination in the matter of goal setting, creating a vision and mission and Planning can lead to valuable results in this field. Determining the competency models of managers in the field of endowment and charity affairs based on new and updated needs to advance affairs in today's world is another necessity to increase the role of benefactors in the development of women's sports facilities. Therefore, it is necessary to select managers in the department of endowments and charities to use people who have the necessary qualifications for a proper management. Managers in this sector must be fully aware of scientific and up-to-date knowledge and information in order to attract and preserve people's capital and have an open vision in this field in order to be able to adapt to the changes in today's world. They should identify new needs (such as women's sports) in the field of endowment and charity and take appropriate steps towards the correct use of the property of benefactors.

Cultural barriers of maintain and attract sports donors in the field of women's sports in the present research were identified based on expert opinion and are verified in confirmative factor analysis. Promoting the culture of endowment in the field of women's sports is through institutionalizing trust and confidence, which should be devoted to the discussion of endowments, efficiency and effects of endowments. In the research of Ghayour Baghbani et al. (2019), the belief base for accepting the worldly and hereafter fruits of donation was introduced as one of the ways to develop the culture of donation in the society. The culture of endowment in Iranian Islamic society has a rich background in the country, but the society's acceptance of any new factor, even though it is useful, requires culture building and strengthening of the cultural foundation in the society. The number of benefactors in the country is significant, and this indicates the existence of the necessary platforms to attract benefactors to the field of sports, and the realization of this is through inviting the public, using scientific and attractive strategies for the culture of creating new endowments in accordance with the new needs of the society. As Taheri Demneh and Heydari Darani (2018) state, for a forward-looking approach to promoting endowment in the field of science and technology, culture-building in charity and endowment in the field of science and technology is essential. In the research of Heydari Fard and Sharifian (2017), the lack of appropriate culture and the lack of a suitable model in the field of sports charity were identified as obstacles to the participation of donors in the development of sports spaces. According to the results of Afroozeh et al.'s research (2018), the component of culture building is one of the components that can have the greatest effect on attracting donors in sports. Cultivation of the endowment should be done in a planned, comprehensive way and by using all available potentials, including media, education, higher education and urban advertising, etc. Creating a culture of dedication in women's sports through measures such as presenting the role of sports and its benefits for women, presenting its short-term and long-term results, etc. can be effective in encouraging the presence of benefactors and proving its spiritual reward. Although the main goal of the benefactors is to receive spiritual reward, but actions such as honoring the sports benefactors by commemorating them as well as setting role models in the field of sports venues can help in the development of the culture of donation in sport.

Among the the barriers to attract and retain sports donors, Information barriers were one of the barriers that were identified in the qualitative analysis and its contribution was confirmed in the quantitative analysis. In general, it can be stated that there is a lack of a correct, coherent and guided system of information and advertising planned to encourage and motivate talented and interested people to enter the path of endowment in the field of sports. Also, insufficient information of benefactors and well-wishers about the need and investment in women's sports infrastructure, in order to allocate their wealth to the mentioned cases, is one of the problems of endowment in the field of women's sports. This obstacle was introduced as one of the obstacles in the organization of endowments in the pathology of the position of the endowment institution in strengthening the country's economy in the research of Khaksar Astana et al. (2015). Also, in the research of Ghayour baghbani et al. (2019), two components of information and advertising in the field of endowment were identified in the identification of factors affecting the development of endowment culture. In line with the results of the research in this section, Caviola et al (2020), in a study investigated the barriers to effective charity, showed that only when people are both properly informed and have the necessary motivation to donate, they will act effectively. Also, Zhang and Hu (2017) investigated the most important factor affecting sports charity in China, and the results show that strengthening the awareness and dedication of citizens is more efficient than using incentive measures in improving the level of sports charity development. It is necessary to pay attention to and inform potential supporters and benefactors about new intentions (such as the development of women's sports infrastructure) through new, attractive and motivating advertising methods in overcoming informational obstacles.

Legal barriers were introduced as another barrier to attract and retain sports benefactors in the development of women's sports infrastructure and ranked fourth in terms of importance in the ranking of barriers. In this regard, legal obstacles were introduced in the research of Khaksar Astana et al. (2015). The meaning of legal challenges in this research is the legal debates about endowments that exist in the civil law and the law on the formation of endowments and charitable affairs; Also, in the research of Ghayor Baghbani et al. (2019), the facilitation of endowment through the amendment of laws and regulations was introduced as one of the solutions to remove the obstacles and bottlenecks of endowment, and the lack of comprehensive and targeted laws in the research of Heydari Fard and Sharifian (2017) was identified as one of the obstacles to the participation of donors in the development of sports spaces. According to the results of Afrozeh et al.'s research (2018), the legal component with three categories of minority, transparency and acceleration is among the components that can have the greatest effect on attracting benefactors and supporters in sports. In order to reduce or eliminate legal obstacles in the field of attracting and maintaining financial sponsors, considering special legal facilitators such as tax exemptions, creating legal requirements for the public sector to support donors and creating protective laws to increase synergy between the public sector, private sector and donors in the field of the development of women's sports infrastructure is recommended to attract and retain donors.

Economic barriers were identified as one of the barriers to attract and retain donors in the field of women's sports infrastructure development. The high price of land and the high price of sports equipment were introduced as economic obstacles to attract donors in this area; also, the lack of extraordinary financial support from the government in supporting benefactors in the construction of sports facilities, especially in women's sports, was one of the other factors in the economic obstacle. Also, although donated assets, such as dedicated sports facilities, are potential wealth, but in order to make these funds flow, it is necessary to spend initial fixed costs. The high cost of maintaining sports facilities was introduced as another obstacle in this section. In the research of Heydari Fard and Sharifian (2016), the high price of land, the high cost of sports equipment and facilities, and the cost of maintenance were identified as one of the obstacles to the participation of donors in the development of sports spaces. Despite the willingness of banks to find suitable ways to grant loans to donated properties and despite the establishment of the country's endowment construction fund, the problem of lack of liquidity as the primary reason for the economic organization of endowments still remains. In the country's endowment investment sector, the approach of maximizing endowment income should be considered. In this view, every endowment should be like a profitable business, and the only difference is that the profit from the activity is used for the donor's intentions. Applying new marketing and income generation strategies is essential for success in this direction.

Conclusion

As the results of the research show, in order to overcome the barriers to attracting and retaining donors in the development of women's sports infrastructure, it is necessary to implement strategies to remove barriers in 5 dimensions. It seems that the most responsibility for removing the obstacles lies with the endowment and charity departments, because the management obstacles are completely related to these types of organizations and they can play an effective role in removing other obstacles.

Acknowledgments

We are also grateful to everyone who helped us in conducting this research.

Conflicts of Interest

No potential conflict of interest was reported by the authors.

Funding

This research received no specific grant from any funding agency in the public, commercial, or not-for-profit sectors.

References

- Abuin-Penas, J., Babiak, K. & Martínez-Patiño, M.J. (2020). Athlete's Philanthropy and Social Responsibility Communication on Social Media during COVID-19. *Journal of Human Sport and Exercise*, 17(1), 1-10. doi: <https://doi.org/10.14198/jhse.2022.171.20>
- Afrozeh, M., Afrozeh, H., Kameli, F. (2018). Identifying the Effective Factors of Donors and Dedication Attracting in Sport. *Sport Management Studies*, 9(46), 157-174. Doi: <https://doi.org/10.22089/smrj.2017.4484.1865> (In Persian)
- Asadi Janati, N., Alimohammadzad Kh., Hosseini, M., Maher, A., Bahadori, M. (2020). Barriers of Efficient and effectiveness participation of Donors in healthcare system, a Qualitative Study. *Iranian Journal of Health Insurance*, 3(1), 43-50. (In Persian)
- Bunds, K., Brandon-Lai, S., & Armstrong, C. (2016). An Inductive Investigation Of Participants' Attachment To Charity Sports Events: The Case Of Team Water Charity. *European Sport Management Quarterly*, 16(3), 364-383. <https://doi.org/10.1080/16184742.2016.1164212>
- Caviola, L., Schubert, S., & Nemirow, J. (2020). The Many Obstacles to Effective Giving. *Judgment and Decision Making*, 15(2), 159-172. <https://doi.org/10.1017/S1930297500007312>
- Ehsani, M., Abu Darda, Z., Iqbali, M. (2008). Investigating the causes of sponsors' lack of support for women's professional sports in Isfahan city. *Journal of Movement and Sports Sciences*, 2(12), 111-120. (In Persian)
- Filipec, M., Matijević, R. (2022). Why We should Recommend Exercise in Pregnancy? *Clinical and Experimental Obstetrics & Gynecology*, 49(11), 243. doi: [10.31083/j.ceog4911243](https://doi.org/10.31083/j.ceog4911243)
- Filo, K., Fechner, D., Inoue, Y. (2019). The Donors Supporting Charity Sport Event Participants: An Exploration of the Factors Driving Donations. *Journal of Sport Management*, 34(5), 1-12. doi: [10.1123/jsm.2019-0253](https://doi.org/10.1123/jsm.2019-0253)
- Filo, K., Hookway, N., Wade, M., Palmer, C. (2022). An exploration of charity sport event donor perceptions of online peer-to-peer fundraising mechanisms. *Sport Management Review*, 25(7), 1-24. <https://doi.org/10.1080/14413523.2021.1993645>
- Filo, K., Funk, D., & O'Brien, D. (2010). The Antecedents and Outcomes of Attachment and Sponsor Image within Charity Sport Events. *Journal of Sport Management*, 24(6), 623-48. doi: [10.1123/jsm.24.6.623](https://doi.org/10.1123/jsm.24.6.623)
- Ghayour baghbani, M., Rojuie, M., Pourang, A., Moradi, M., Nasr Abadi, H. (2019). Identifying Factors Affecting the Development of "Waqf" Culture through a Content Analysis Approach at Razavi Holy Shrine. *Islamic Management Quarterly*, 27(2), 149-170. <https://dori.net/dor/20.1001.1.22516980.1398.27.2.7.7> (In Persian)
- Hamidpour, H., and Shetab Booshehri, N. (2015). The role of mass media in the development of women's sports championship Principals Office of Youth and Sports has been in Khuzestan Province. *Communication Management in Sport Media*, 2(4), 48-60. https://sportmedia.journals.pnu.ac.ir/article_1925.html?lang=en (In Persian)
- Hassan Shahi, H., Ghahreman Tabrizi, K., Sharifian, I. (2017). Evaluation of the position of waqf and sports charity among the donors of Kerman province. *The first national conference of sports and health science achievements of Abadan University of Medical Sciences*, Ahvaz. (In Persian)
- Heydari fard, S., Sharifian, E. (2017). Identification and Comparison of Barriers to Donor's Contributions to Development of Sport Facility. *Sport Management Studies*, 9(41), 81-96. <https://doi.org/10.22089/smrj.2017.916> (In Persian)
- Hosseini, M., Ebrahimi Salari, T., Mazloun Khorasani, A. (2013). Improving management methods in the endowment organization and its effect on increasing productivity in the endowment field. *Two Scientific-Research Quarterly Journals of Islamic Management*, 21(1), 105-125. (In Persian)
- Hutcheson, G. D., and Sofroniou, N. (1999). *The Multivariate Social Scientist: an introduction to generalized linear models*. Sage Publications.
- Inoue, Y., Heffernan, C., Yamaguchi, T. & Filo, K. (2017). Social And Charitable Impacts Of A Charity-Affiliated Sport Event: A Mixed Methods Study. *Sport Management Review*, 21(2), 218-202. <https://doi.org/10.1016/j.smr.2017.06.005>
- Jamaat, Kh., Ehsani, M. (2011). Direct and indirect objectives of financial support for sports in Iran. *Research in Sports Sciences*, 10, 57-72. (In Persian)

- Khaksar Astana, H., Rahnama, A., Ebrahimi, H. (2015). Analysis of the position of the endowment institution in the strengthening of the country's economy. *the first conference on the knowledge base of resilience economy*, Islamic Azad University, Tafresh. (In Persian)
- Kim, M. & Walker, M. (2013). The Influence of Professional Athlete Philanthropy on Donation Intentions. *European Sport Management Quarterly*, 13(5), 1-23. <https://doi.org/10.1080/16184742.2013.837942>
- Ko, Y., Rhee, Y., Walker, M., Lee, J. (2014). What Motivates Donors to Athletic Programs: A New Model of Donor Behavior. *Nonprofit and Voluntary Sector Quarterly*, 43(3), 523–546. <https://doi.org/10.1177/0899764012472065>
- Murphy, J., Mcgrane, B., Sweeney, M. (2021). Physical Activity, Mental Health and Wellbeing of Irish Adolescents during Covid-19 Restrictions. A Re-Issue of the Physical Activity and Wellbeing Study (PAWS). *Physical Activity and Health*, 5(1), 215–228. <https://doi.org/10.20944/preprints202107.0580.v1>
- Nazari Azad, M., Talebpour, K., Kashani, M. (2020). Sociological Analysis of Gender Inequality in Sport (The Perspective of Female National Hero Athlete). *Woman and society*, 10(40), 289-316. (In Persian)
- Nuseir, M. (2020). The Effects of Sponsorship on the Promotion of Sports Events. *International journal of Business Innovation and Research*, 22(2), 191-207. [doi: 10.1504/IJBIR.2020.107838](https://doi.org/10.1504/IJBIR.2020.107838)
- Pourgachi, S., Heydarinejad, S., Shetab Bushehri, N., Khatibi, N. (2017). Identification of obstacles to the promotion of female athletes in the Premier League of Khuzestan province. *Sport Management Studies*, 9(42), 137-162. https://smrj.ssric.ac.ir/article_1001.html?lang=en (In Persian)
- Salimi, M., Moslehi, L., Labbaf, A. (2022). Designing a model of cultural barriers for women's participation in leisure sports activities in sports recreation centers. *Journal of Strategic Sociological Studies in Sport*, 1(1), 31-45. (In Persian)
- Seyyed Ameri, M., Moharramzadeh, M., Bashiri, M., Hadi, H. (2009). Obstacles of Attracting Sponsorship in the Sport Industry of East Azarbaijan Province. *The journal of productivity management*, 3(10), 164-174. <https://dorl.net/dor/20.1001.1.27169979.1388.3.3.6.1> (In Persian)
- Seyed Bagheri, M., Sharifian, E. (2017). Identifying and prioritizing barriers to sponsorship of private companies of sport of champions. *Journal of Research in Sport Management & Motor Behavior*, 7(13), 69-80. (In Persian)
- Shah Hosseini, P. (2010). Educational Dedication - A Cultural Geographical Approach. *Journal of Geography*, 8(24), 87-99. (In Persian)
- Taheri Demneh, S., and Heidari Darani, T. (2018). Thinking in The Role of Waqf and Charity Affair in The Field of Science and Technology. *Science and technology policy*, 8(1), 39-48. https://stpl.ristip.sharif.ir/article_21107.html?lang=en (In Persian)
- Wooda, L., Snelgroveb, R., & Danylchuka, K. (2010). Segmenting volunteer fundraisers at a charity sport event. *Journal of Nonprofit & Public-Sector Marketing*, 22(1), 38-54. <https://doi.org/10.1080/10495140903190408>
- Zhang, L., & Hu, J. (2017). Exploring the Most Important Factor of Chinese Sports Charity by Using System Dynamics Simulation. *Proceedings of the Tenth International Conference on Management Science and Engineering Management*, 71-86. https://doi.org/10.1007/978-981-10-1837-4_7
- Zhang, J., Kim, E., Mastro Martino, B., Qian, T., Nauright, J. (2018). The sport industry in growing economies: critical issues and challenges. *International Journal of Sports Marketing and Sponsorship*, 19(2), 110-126. <https://doi.org/10.1108/IJSMS-03-2018-0023>
- Zhao, J. (2022). Research Status of Sports Industry Laws from the Perspective of Knowledge Graph. *Security and Communication Networks*, (4), 1-11. <https://doi.org/10.1155/2022/6541921>